

W. B. CARPENTER.

Centering Device for Wood Turning Lathes.

No. 161,384.

Patented March 30, 1875.

Fig. 1.

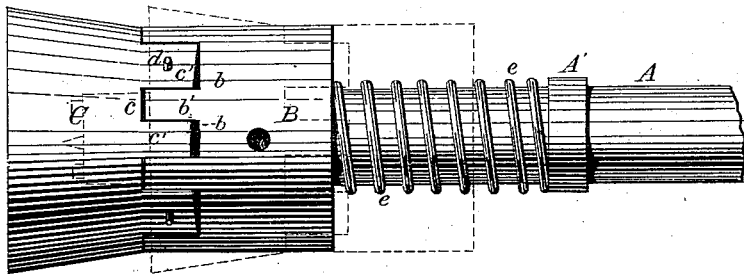

Fig. 2.

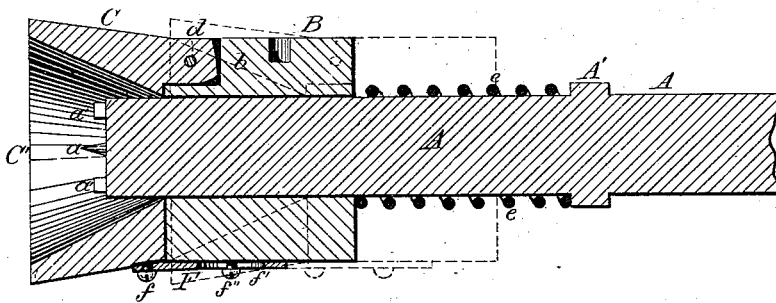
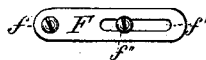

Fig. 3.



Attest:
My hand and seal
Edw. W. Down

Inventor:
Ward B. Carpenter
By N. Crannford atty.

UNITED STATES PATENT OFFICE.

WARD B. CARPENTER, OF TOPSHAM, ASSIGNOR OF ONE-HALF HIS RIGHT TO LANE MANUFACTURING COMPANY, OF MONTPELIER, VERMONT.

IMPROVEMENT IN CENTERING DEVICES FOR WOOD-TURNING LATHES.

Specification forming part of Letters Patent No. 161,384, dated March 30, 1875; application filed February 1, 1875.

To all whom it may concern:

Be it known that I, WARD B. CARPENTER, of Topsham, in the county of Orange, in the State Vermont, have made certain Improvements in a Centering Device for Wood-Turning Lathes, of which the following is a specification:

And it consists in the construction of the device, as will be fully hereinafter described.

In the drawings, Figure 1 is a side view of the device, and Fig. 2 represents a longitudinal sectional view of the same.

A represents the spindle of a wood-turning lathe, with collar A', and the usual center point *a* and driving-dogs *a'*. B is a sliding sleeve, freely sliding upon the spindle A, and has mortises *b* and tenons *b'* in it to form half a hinge. C is a centering-funnel, with its funnel-shaped opening C', and hinged to sleeve B by the mortises *c* and tenons *c'* interlocking with the mortises *b* and tenons *b'* on sleeve B, and turning upon the pintle *d*, as seen in Figs. 1 and 2. *e* is a spiral or other spring around the spindle A, and between the sliding sleeve B and collar A'. F is a slotted plate made fast to the centering-funnel C by screw *f*, extends along the side of sleeve B opposite to the hinge in C and B, and can be secured at any point within the range of slot *f'* by turning screw *f''* hard down upon it.

It is well known that in turning many small things—such as thread-spools, bobbins, and the like, where the blank is split from a block—that the grain is not always at right angles to the end of such blank; hence, as one corner projects more than the other, it is impossible to insert properly the blank into the ordinary centering device of a lathe, so as to have it truly centered. This device is intended to obviate this difficulty, and make it as easy to center blanks split from blocks as those sawed with ends at right angles with the sides.

The relative position of the centering-funnel, and the center point *a*, and driving-dogs *a'*, when a blank is to be inserted, is shown at Fig. 2, where the funnel C' projects beyond

the center point and driving-dogs of spindle A; but when a blank is inserted into the funnel C' it is centrally held, while the funnel and sleeve are forced back, contracting the spring, until the center-pin *a* takes into the center of the blank, and the driving-dogs are forced into their place truly, and the carriage that carries the knife that is used to cut the wood into shape is or may be the means of forcing the centering-funnel back, to expose the end of the spindle A, as seen in dotted lines in Fig. 2, or the centering-funnel may be forced back by other mechanical means—such as a weight, cord, and pulley.

The true way to put a blank into the centering-funnel, where the end is not at right angles to the sides, is to place the longest side toward the hinge of funnel and sleeve, the funnel having been previously adjusted to the proper inclination, and fixed by the screw on slotted piece, or by some equivalent arrangement. The blank will be guided centrally upon the center point of the spindle.

Where the funnel has been forced back from the end of the spindle by the forward or sidewise movement of the tool-carriage, the funnel will return to its original position upon the backward movement of the tool-carriage, and be ready for the insertion of a new blank.

The plate F, when the deflection is known that will fit the angularity of the end of the blank, can be secured to the sleeve by the holding-screw *f''* in the slot *f'* of the plate, where it will remain until necessary to change the same to fit the end of a blank having a different angle.

The sleeve B and cup C may revolve with the spindle A, or the spindle may revolve and the sleeve and cup remain stationary.

I am aware that funnel-shaped centering devices have been attached to lathes. I am also aware such funnel-shaped centering device is used with a sliding sleeve; but

What I do claim, and desire to secure by Letters Patent, is—

1. A centering device for a lathe, composed

of the sliding sleeve B, hinged or pivoted at one side to the funnel-shaped centering-cup C, as and for the purpose described.

2. The combination of the funnel-shaped cup C, sleeve B, hinged together as described, with the holding-strap F, constructed substantially as and for the purpose described.

3. The funnel-shaped centering-cup C,

hinged or pivoted to and adjusted with relation to the sliding sleeve B by the strap F, in combination with springs *e*, as and for the purposes described.

WARD B. CARPENTER.

Witnesses:

JAMES D. BROCK,
MAHLON TAPLIN.